

**600-2707
PCI EXPRESS
EXPANSION SYSTEM
USER'S MANUAL**

The information in this document has been carefully checked and is believed to be entirely reliable. However, no responsibility is assumed for inaccuracies. Furthermore, Cyclone Microsystems, Inc. reserves the right to make changes to any products herein to improve reliability, function, or design. Cyclone Microsystems, Inc. neither assumes any liability arising out of the application or use of any product or circuit described herein, nor does it convey any license under its right or the rights of others.

Revision 1.0, June 2010

Cyclone P/N 800-2707

Copyright 2010 by Cyclone Microsystems, Inc.

CONTENTS



CHAPTER 1

1.1 INTRODUCTION	1-1
1.2 SPECIFICATIONS.....	1-3
1.3 STANDARDS	1-3
1.4 ORDERING INFORMATION	1-3

CHAPTER 2

2.1 THEORY OF OPERATION	2-1
-------------------------------	-----

CHAPTER 3

3.1 600-2707 CHASSIS.....	3-1
3.2 SEATING OF CARDS	3-1
3.3 CHASSIS COOLING	3-1
3.4 CHASSIS POWER	3-2
3.5 LIGHT LOADING.....	3-2
3.6 POWER CONSIDERATIONS.....	3-2
3.7 PCI-E AUXILIARY POWER CONNECTORS	3-3

CHAPTER 4

4.1 SYSTEM POWER UP	4-1
4.2 SEATING OF CARDS	4-1
4.3 PCIe-426 HOST BUS CABLE ADAPTER	4-1
4.3.1 PCIe-426 Power	4-1
4.3.2 PCIe-426 Mechanical	4-1
4.3.3 PCIe-426 LED Indicators.....	4-1
4.3.4 PCIe-426 Output Swing, De-Emphasis and Receive Equalization.....	4-2
4.4 LINK INDICATION - LED DEFINITION PCIe-427	4-2

CHAPTER 5

5.1 PHYSICAL CONFIGURATION.....	5-1
---------------------------------	-----

CHAPTER 6

6.1 REFERENCE MANUALS	6-1
-----------------------------	-----

LIST OF FIGURES

Figure 1-1. 600-2707 Block Diagram 1-2
Figure 5-1. PCIe-427 Physical Configuration..... 5-1
Figure 5-2. PCIe-426 LEDs..... 5-2
Figure 5-3. PCIe-426 Physical Configuration..... 5-2
Figure 5-4. 600-2707 Chassis Drawing 5-3
Figure 5-5. 600-2707 Chassis..... 5-3

LIST OF TABLES

Table 1-1. Specifications 1-3
Table 3-1. Slot Capabilities..... 3-1
Table 3-2. load Register Jumpers..... 3-2
Table 3-3. PCIe-427 Power Requirements..... 3-3
Table 3-4. PCIe-426 Power Requirements..... 3-3
Table 3-5. Power Supplied Per PCIe Slot..... 3-3
Table 3-6. PCI-E Auxiliary Power Connector 3-4
Table 4-1. PCIe-426 Default DIP Switch Configuration 4-2
Table 4-2. Link LED Indication..... 4-3

1.1 INTRODUCTION

The Cyclone Microsystems 2707 PCI Express Gen2 Expansion System is a PCI Express (PCIe) expansion system that allows the user to add up to five PCI Express add-in-cards. Most PCs contain few PCI Express slots making them poorly suited for embedded systems requiring many different I/O boards and co-processor resources.

The 2707 PCI Express Expansion System permits system developers to use powerful and cost-effective PCs as a foundation for a robust embedded system. The five PCI Express slots are organized as three x16 slots and two x8 slots and are all Gen2 capable. All expansion slots accommodate full length and full height cards and are cooled by one 120 CFM and two 59 CFM fans. A 650 watt supply powers the rack mounted expansion chassis.

The Expansion System supports 80 Gb/s bi-directional traffic to and from the host system. The system utilizes repeaters and non-blocking PCI Express switches for excellent peer-to-peer I/O bandwidth. For PCs with modern BIOSs, the 2707 Expansion System is recognized by the host system upon boot-up, requires no hardware specific drivers and is entirely host operating system agnostic.

The 600-2707 system is composed of three elements: a PCI Express Host Bus Cable Adapter, an Expansion System Cable and an Expansion Chassis. The PCIe-426 Host Bus Cable Adapter card is to be inserted into a host computer's x16 PCIe Gen2 slot. The x16 PCIe expansion cable links the PCI host with the expansion chassis. The expansion chassis is populated with the PCIe-427 Switched Backplane.

PCI Express is a high performance, general purpose I/O inter-connect defined for a wide variety of computing and communication platforms. Key PCI attributes, such as its usage model, load-store architecture, and software interfaces are maintained, whereas its parallel bus implementation is replaced by a serial interface. PCI Express take advantage of recent advances in point-to-point inter-connects, Switch-based technology, and packetized protocol to deliver new levels of performance.

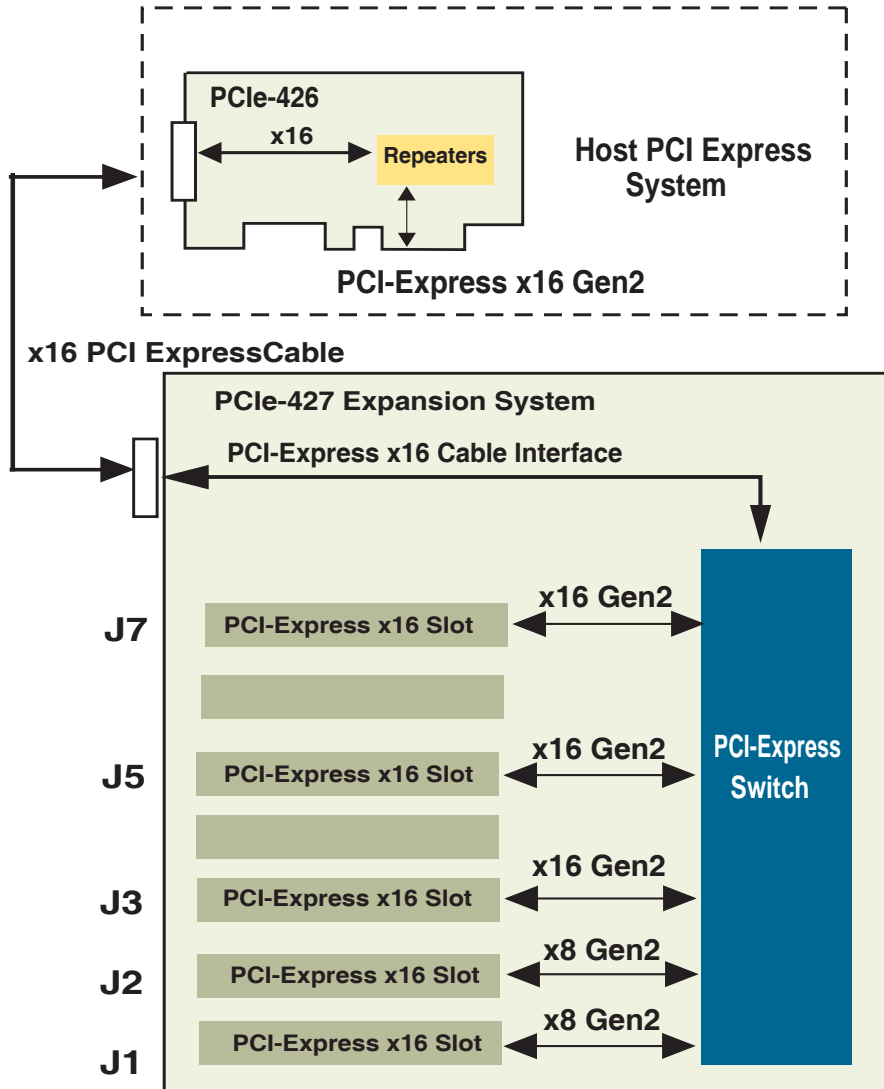

Figure 1-1. 600-2707 Block Diagram

1.2 SPECIFICATIONS

The specifications in Table 1-1 detail the 600-2707 Expansion System chassis including the PCIe-427 expansion backplane and the 650W power supply. The chassis also includes one 120 CFM and two 59 CFM fans.

Table 1-1. Specifications

Physical	Height	7 inches
	Width	17 inches
	Depth	22 inches
	Other	19 inch rack mountable
Electrical	Voltage	115/230 VAC
	Frequency	60Hz/50Hz.
	Input Current	10 A for 115 VAC, 5.0 A for 230 VAC.
	Inrush Current	60 A max. for 115 VAC
Environmental	Operating Temperature	0 to 50 Degrees Celsius
	Relative Humidity	0% to 95% (non-condensing)
	Storage Temperature	-20 to 70 Degrees Celsius

1.3 STANDARDS

PCI Express Base Specification Revision 2.0

PCI Express Card Electro Mechanical Specification 2.0

PCI Express External Cabling Specification 2.0

1.4 ORDERING INFORMATION

The expansion system is available with one or three meter cables and standard or low profile panels on the Host Bus Adaptor (PCIe-426).

Cyclone Part Numbers	
600-2707-3SH	Expansion System with 3 meter cable and standard height panel
600-2707-1SH	Expansion System with 1 meter cable and standard height panel
600-2707-3LP	Expansion System with 3 meter cable and low profile panel
600-2707-1LP	Expansion System with 1 meter cable and low profile panel

2.1 THEORY OF OPERATION

The basic PCI Express link consists of dual unidirectional differential links, implemented as a transmit pair and a receive pair. The signaling rate for PCI Express Gen2 is 5.0 Gigabits/second/Lane/direction. A link supports at least one lane.

The PCI Express link from the PCIe-426 over the cable to the PCIe-427 is a sixteen lane (x16) link. The PCIe-427 provides three x16 slots (slots J3, J5, J7) and two x8 slots (slots J1 and J2). All slots are populated mechanically with x16 connectors; the upper eight lanes of slots J1 and J2 are not connected. All slots can accommodate either single lane (x1), x4, x8 or x16 add-in cards. Although not expressly permitted by the PCI Express Specification, slots J1 and J2 accommodate “down-shifting” a x16 card into a x8 slot. Plugging a smaller link card into a larger link connector is fully allowed.

Once the PCIe-426 is installed into the host PC, the cable connected to the PCIe-427, the chassis plugged into an AC power outlet and any desired add-in cards are installed, the system is ready to be turned on. When the host is turned on, a signal from the PCIe-426 will turn on the PCIe-427 chassis. A number of things happen at this point. First, the PCI Express links are initialized. This is a purely hardware initialization where each PCI Express link is set up following a negotiation of lane widths by the two ends of each link. No firmware or operating system software is involved. Once the links are initialized or “trained”, there are LED indicators on each of the Cyclone Microsystems cards that indicate the links are trained. A detailed explanation of the LEDs follows later in this manual.

One essential requirement for system initialization is the ability of the host system’s BIOS to be able to enumerate the many bridges inherent in a complex PCI Express design. The links from the PCIe-426 to the PCIe-427 are created with PCI Express Switches. Each link looks like a PCI-to-PCI bridge to the Host’s BIOS. The number of bridges can add up quickly. Older BIOS may not have the resources to enumerate the number of bridges. Make sure that the BIOS on the host computer has the latest updated BIOS. If required, contact the host system’s manufacturer to make sure that the BIOS used can handle the large number of bridges that it will see in the system.

3.1 600-2707 CHASSIS

The PCIe-427 Expansion Backplane is installed into a seven slot rack mountable chassis. The chassis provides access to all five PCI Express slots. All slots can accommodate standard height and full length PCI Express add-in cards. The chassis also contains three drive bays that may be used to install peripheral devices for specific applications. There are several four pin peripheral power connectors, floppy drive connectors and SerialATA connectors available from the power supply.

3.2 SEATING OF CARDS

Unlike standard PC applications, the 2707 Expansion Systems has a narrow lower gate that precisely engages the lower end of the PCI Express Add-In board's face panel. The purpose is to ensure correct electrical connector mating of up-plugged boards. Failure to accurately mate the lower end of the face panel with the chassis lower gate will lead to the board not being recognized by the host.

All five slots of the PCIe-427 have x16 connectors but only three slots (J3, J5 and J7) have the full x16 lane connection to the switch. Slots J2 and J3 have a x8 lane connection to the switch. Slots J5 and J7 will support a double width PCIe add-in card such as a graphics board with a heat sink. Slot J3 will also support a double width add-in card, provided no cards are installed in slot J2. The following table summarizes the slot capabilities

Table 3-1. Slot Capabilities

Slot	Connector	Lanes	Widtht
J1	x16 connector	x8 lanes	single
J2	x16 connector	x8 lanes	single
J3	x16 connector	x16 lanes	single (double if no card installed in J2)
J5	x16 connector	x16 lanes	double
J7	x16 connector	x16 lanes	double

3.3 CHASSIS COOLING

Airflow in the 600-2707 chassis is provided by one 120 CFM fan located at the front of the chassis and two 59 CFM fans located at the rear of the chassis.

3.4 CHASSIS POWER

The chassis contains a 650W ATX12V (v2.31) power supply with three independent 12V outputs, which are distributed among the PCIe-427s facilities to prevent overloading of any one output. The PCIe-427 can support 65W of +12V power at all five slots. Assuming the cards also draw the maximum 10W from +3.3V, then a fully populated chassis would have about 70W surplus power available for peripheral components.

3.5 LIGHT LOADING

Because the power supply has been sized for a fully populated chassis, when in placed under light loading, the supply may not stay in regulation. Symptoms of a supply that is not regulating properly are loss of link back to the host (green “CABLE” LEDs are not ON) or a chassis that powers up momentarily, then turns OFF. To hedge against this situation, the PCIe-427 has on-board load resistors that can be jumpered into service. Users can selectively load the +12V1 and +12V2 rails as required for their application. The +12V1 rail services slots J1, J2 and the six position PCIe auxiliary power connectors. If these slots and connectors are not used or are lightly loaded, then install the jumper shunt across the pins of J21. The +12V2 rail services slots J3, J5 and J7. If these slots are not used or are lightly loaded, then install the jumper shunt across the pins of J22. The minimum loading requirements of the +3.3V, +5V and +12V3 rails are satisfied by the PCIe-427 circuitry, there are no jumper selections to be made.

Table 3-2. Load Resistor Jumpers

Jumper	Voltage Rail	Services
J21	+12V1	J1, J2, PCIe aux
J22	+12V2	J3, J5, J7

3.6 POWER CONSIDERATIONS

Table 3-1 through 3-3 show the power consumption for the Cyclone Microsystems boards and the power supplied to PCI Express slots. Note that the PCIe-426 is installed in and powered by the host supply. Consequently, the PCIe-426 should not be included as a component of the Expansion Chassis power budget.

Table 3-3. PCIe- 427 Power Requirements

Voltage	Current Minimum	Current Typical	Current Maximum	Where Used
+3.3V	0.100 Amps	0.65 Amps	15A + 0.65 Amps	All slots & baseboard
+5V	0.200 Amps	0.200 Amps	0.200 Amps	Not used *
+12V-1	0.500 Amps**		10.8 Amps	Slots J1, J2 and PCIe aux cable
+12V-2	0.500 Amps***		16.2 Amps	Slots J3, J5, J7
+12V-3	N/A	9.00 Amps	17.00 Amps	Baseboard

* Other than the minimum loading, the +5V supply is not used by the PCIe-427.

** Using jumper J21, this minimum load can be optionally added to help stabilize lightly loaded supplies.

*** Using jumper J22, this minimum load can be optionally added to help stabilize lightly loaded supplies.

Table 3-4. PCIe- 426 Power Requirements

Voltage	Current Typical	Current Maximum
+3.3V	1.09 Amps	1.60 Amps
+12V	0 Amps	0 Amps

* The PCIe-426 does not use +12V

Table 3-5. Power Supplied Per PCIe Slot

Voltage	Current Maximum	Voltage Tolerance
+3.3V	3.0 Amps	+/- 9%
+12V	5.5 Amps	+/- 8%

3.7 PCI-E AUXILIARY POWER CONNECTORS

Some PCIe add-in cards require more power than the PCIe slot connector can provide. These cards will have a six position, two row by three column, Molex type power connector probably located at the top or rear edge of the card. The power supply in the expansion chassis has two PCIe auxiliary power cables labeled “PCI-E” available for these card types. If a customer application requires a third PCIe add-in card with an auxiliary power connector, then J11 on the expansion backplane is available for this purpose.

Customers can make their own cable to connect J11 on the backplane to their third PCIe add-in card. A typical connector housing is Molex 39-01-3065 (black nylon) but there are several other housings in this series that will work. This connector style uses discrete contacts crimped to the wires and inserted into the housing. Typical contact is Molex 39-00-0060 for 18-24AWG wire. The crimping tool is Molex 63819-0900. The pinout of J11 matches the power supply connectors; pins 1-2-3 are +12V (yellow) and pins 4-5-6 are ground (black). Each contact position is labeled on the housing at the wire insertion openings

Table 3-6. PCI-E Auxiliary Power Connector

J11-1	+12V (yellow)
J11-2	+12V (yellow)
J11-3	+12V (yellow)
J11-4	GND (black)
J11-5	GND (black)
J11-6	GND (black)
Mating housing (typ)	Molex 39-01-3065
Contact (18-24AWG)	Molex 39-00-0060
Crimping tool	Molex 63819-0900

4.1 SYSTEM POWER UP

The host PC with the PCIe-426 installed controls power-up for the entire system. The PCI Express cable should be connected between the PCIe-426 and the PCIe-427 and the 600-2707 power cord should be connected to the chassis and plugged into a power socket. There is a power button on the front of the 600-2707 Expansion Chassis, however, it is not connected and serves no practical purpose in this application. When the host PC is powered on, a signal is sent over the PCI Express cable to turn on the 600-2707. If the chassis does not power up, make sure that all cards are seated properly, the chassis is plugged in and the PCI Express cable is connected properly. There is only one LED on the front of the expansion chassis that has meaning. The green LED indicates that the chassis is powered.

4.2 SEATING OF CARDS

Unlike standard PC applications, the 2707 Expansion Systems has a narrow lower gate that precisely engages the lower end of the PCI Express Add-In board's face panel. The purpose is to ensure correct electrical connector mating of up-plugged boards. Failure to accurately mate the lower end of the face panel with the chassis lower gate will lead to the board not being recognized by the host.

4.3 PCIe-426 HOST BUS CABLE ADAPTER

The PCIe-426 Host Bus Cable Adapter is installed in a host computer's x16 Gen2 slot providing an interface from the host to the x16 cable and, in turn, the expansion chassis. It can also be plugged into Gen1 x16 slots, reducing performance.

4.3.1 PCIe-426 Power

The PCIe-426 only uses +3.3V power from the host, see Table 3-2.

4.3.2 PCIe-426 Mechanical

The PCIe-426 is a low profile PCI Express add-in card and is available with either a standard height front panel or a low profile front panel. See Figure 5-3 for a mechanical drawing of the card and Figure 5-2 for a front panel drawing.

4.3.3 PCIe-426 LED Indicators

The bottom (or left) LED on the front panel is the "Cable Present Detect" LED. This LED reflects the status of the "CPRSNT#" signal in the PCIe Expansion Cable. When the LED is ON, it is indicating that the "CPRSNT#" signal is asserted. The PCIe-427 chassis asserts "CPRSNT#" to indicate that it is present, the cable is connected and power is good. If this LED is OFF, there may be a problem with +3.3V power in the expansion chassis or the PCIe Expansion Cable is not connected properly.

The top (or right) LED on the panel is "Expansion System Signal Detect". The LED is on when the PCIe-426 detects a signal on Lanes 0-3 of the PCIe cable. The LED ON indicates normal operation. If the LED is not on, there is something wrong with the cable or the expansion system is not operating properly.

4.3.4 PCIe-426 Output Swing, De-Emphasis and Receive Equalization

The transceiver silicon used on the PCIe-426 has eight steps of programmable de-emphasis, four steps of output swing and eight steps of receive equalization. The PCIe-426 has three DIP switches to adjust these settings on the cable interface. The as-shipped-default DIP switch configuration is what Cyclone Microsystems has determined is the best setting for both the 1m and 3m PCIe cables shipped with Cyclone PCIe Expansion systems. Users should not change the DIP switch settings unless they have the proper test equipment to verify their results. Users change de-emphasis, output swing and receive equalization at their own peril. The default DIP switch configuration is shown below:

Table 4-1. PCIe-426 Default DIP Switch Configuration

POSITION	SWITCH S1	SWITCH S2	SWITCH S3
1	OFF	OFF	ON
2	OFF	ON	ON
3	ON	OFF	ON
4	ON	ON	ON

4.4 LINK INDICATION - LED DEFINITION PCIe-427

The PCIe-427 has twelve green LEDs to indicate the link status of each slot and the cable. Each slot and the cable has two, redundant, LED link status indicators. Six surface mount LEDs, one for each slot and one for the cable are arranged in a row in the corner of the board where the cable enters, see Figure 5-2. The LEDs are labeled J1, J2, J3, J5, J7 and CABLE.

Five surface mount LEDs are placed adjacent to each slot. The LEDs are placed just off axis to the bottom side of an installed board so as not to be obscured by components on the board. The LEDs are labeled SLOT J1 through SLOT J7. The last LED is seen through the back panel next to the PCI Express expansion cable connector to indicate that the link between the PCIe-427 and the PCIe-426 has been established.

A fully functional link (all lanes used and operating at Gen2 rates) will have its LED ON solid. A link running at Gen1 rates and/or using less lanes than available will indicate status with a blinking LED. The LEDs indicate link status as follows:

Table 4-2. Link LED Indication

OFF	Link is down
ON	Link is up, all lanes, Gen2 (5GT/s) rate.
BLINK: 0.5 seconds ON, 0.5 seconds OFF	Link is up, reduced lanes, Gen2 (5GT/s) rate)
BLINK: 1.5 seconds ON, 0.5 seconds OFF	Link is up, all lanes, Gen1 (2.5GT/s) rate).
BLINK: 0.5 seconds ON, 1.5 seconds OFF	Link is up, reduced lanes, Gen1 (2.5GT/s) rate).

5.1 PHYSICAL CONFIGURATION

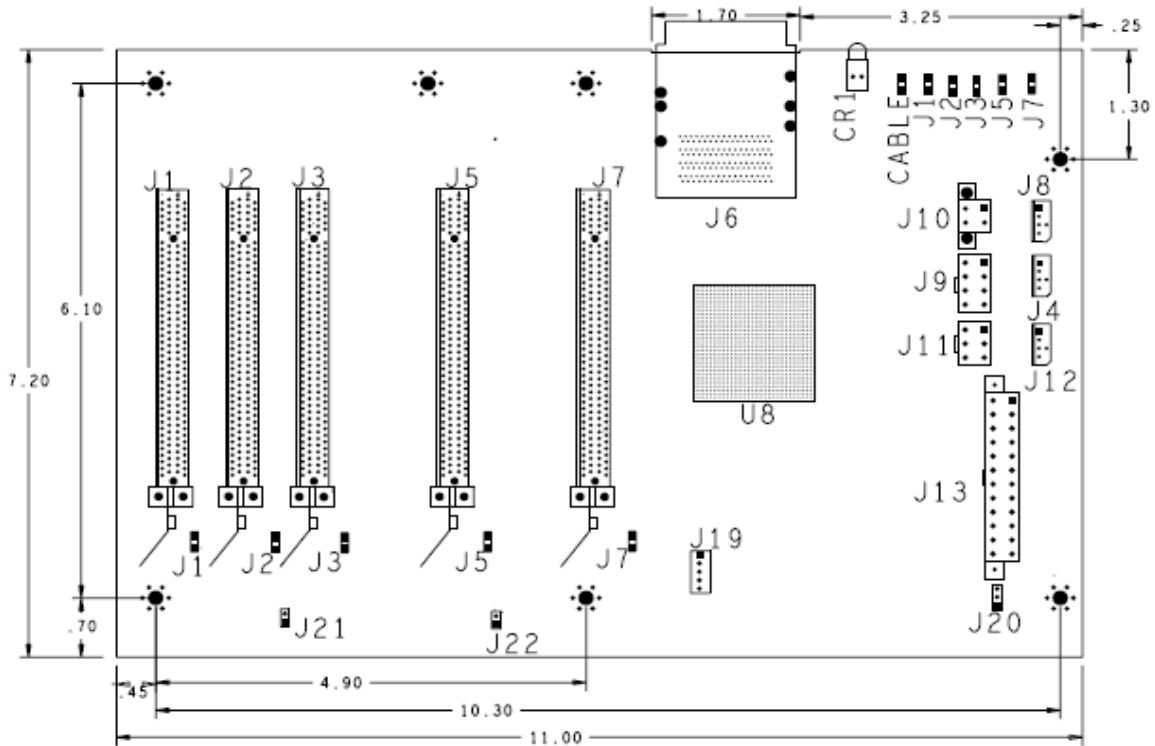

** Dimensions in Inches**

Figure 5-1. PCIe-427 Physical Configuration

Figure 5-1 is a physical diagram (not to scale) of the PCIe-427 backplane, showing the location designators of jumpers, connectors, and major ICs. Refer to this figure when component locations are referenced in the manual text.

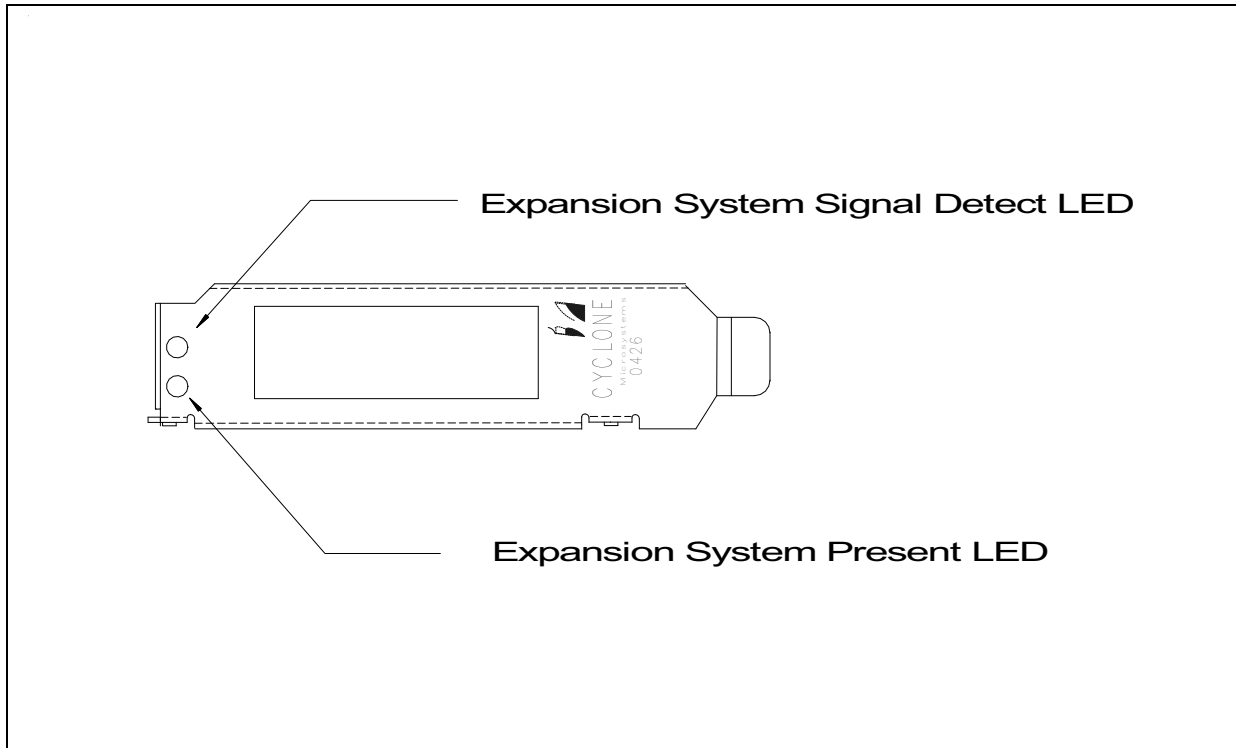

Figure 5-2. PCIe-426 LEDs

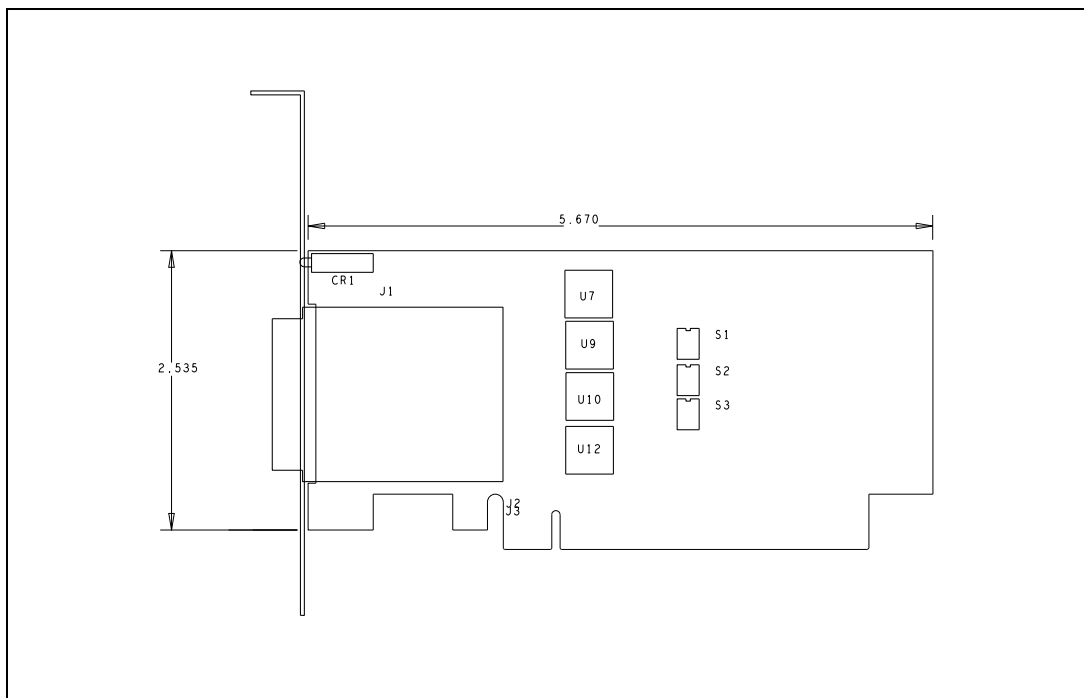

Figure 5-3. PCIe-426 Physical Configuration

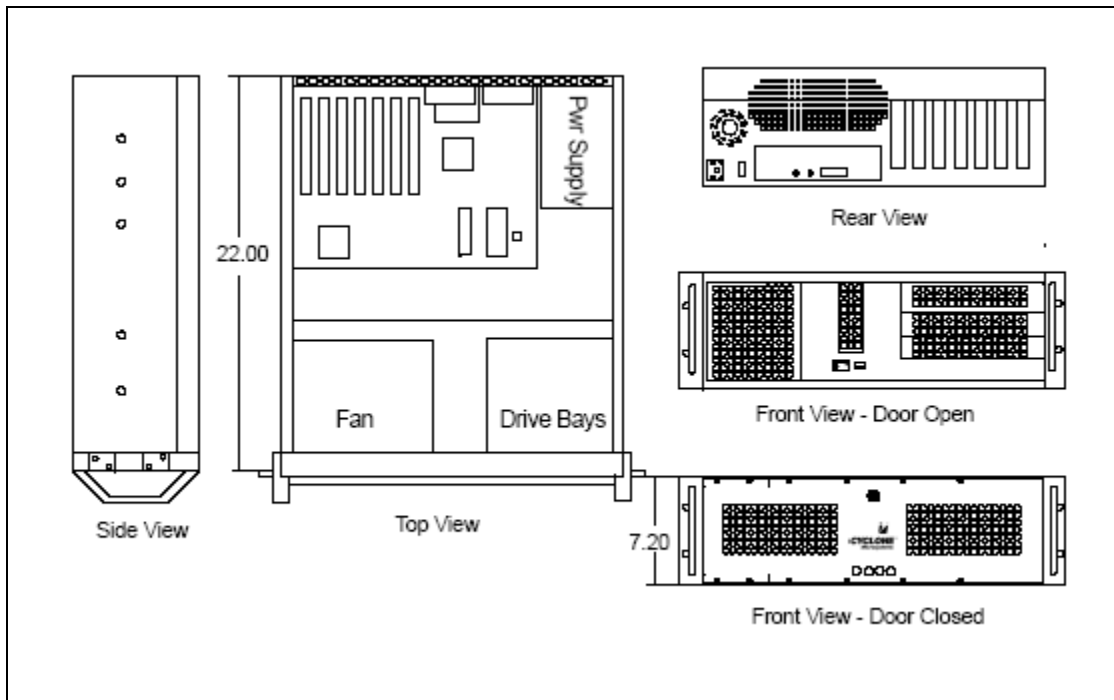

Figure 5-4. 600-2707 Chassis Drawing



Figure 5-5. 600-2707 Chassis

6.1 REFERENCE MANUALS

PEX 8680 80-Lane, 20-Port PCI Express Gen2 Multi-Root Switch Data Book Version0.87

PLX Technology, Inc.
Sunnyvale, CA
(800) 759-3735
www.plxtech.com

PCI Express Base Specification Revision 2.0

PCI Express Card Electromechanical Specification Revision 2.0

PCI Express External Cabling Specification Revision 2.0

PCI Local Bus Specification Revision 2.2

PCI-X Addendum Revision 1.0

PCI Special Interest Group (PCISIG)
5440 SW Westgate Dr., #217 Portland OR 97221
(503) 291-2569
(503) 297-1090 (Fax)
www.pcisig.org